

PowerLogic power-monitoring units

PM5350 power meter

Technical data sheet



PM5350

Functions and characteristics

PE60278



PowerLogic PM5350.

The PowerLogic PM5350 power meter offers all the measurement capabilities required to monitor an electrical installation in a single 96 x 96 mm unit extending only 44 mm behind the mounting surface.

With its large display, all three phases and neutral can be monitored simultaneously. The bright, anti-glare display features large characters and powerful backlighting for easy reading even in extreme lighting conditions and viewing angles. The meter menus are understood by all, with the availability of two languages (English/Chinese) included standard in the PM5350.

Its compact size and high performance make the PowerLogic PM5350 suitable for many applications.

Applications

- Panel instrumentation.
- Cost allocation or energy management.
- Electrical installation remote monitoring.
- Alarming with under/over, digital status, control power failure, meter reset, self diagnostic issue.
- Circuit Breaker monitoring and control with relay outputs and whetted digital inputs.

Main characteristics

Easy to install

Mounts using two clips, no tools required. Ultra compact meter with 44mm depth connectable up to 480 VL-L without voltage transformers for installations compliant with category III, as per IEC 61010-1. See specification table for UL voltage limits.

Easy to operate

Intuitive navigation with self-guided, language selectable menus, six lines, four concurrent values. Two LEDs on the meter face help the user confirm normal operation (heartbeat/communications indicator LED: green and other LED orange, customizable either for alarms or energy pulse outputs).

Easy circuit breaker monitoring and control

The PM5350 provides two relay outputs (high performance) with capability to command most of the circuit breaker coils directly. In addition, monitored switches can be wired directly to the meter without external power supply.

System status at a glance

Bright, anti-glare, backlit display plus two LEDs; orange for energy pulse or alarm and green for heartbeat/communications indication.

IEC 62053-22 class 0.5S accuracy for active energy

Accurate energy measurement for cost allocation.

Power Quality analysis

The PM5350 offers THD and TDD measurements as standard. Total Demand Distortion is based on a point of common coupling (PCC), which is a common point that each user receives power from the power source. The TDD compares the contribution of harmonics versus the maximum demand load.

Load management

Peak demands with time stamping are provided. Predicted demand values can be used in basic load shedding applications.

Alarming with time stamping Over 30 alarm conditions, such as under/over conditions, digital input changes, and phase unbalance inform you of events. A time-stamped log maintains a record of the last 40 alarm events.

Load timer

Load timer setpoint adjustable to monitor and advise maintenance requirements.

Performance Standard Meets IEC 61557-12 PMD/S/K70/0.5.

PM5350

Functions and characteristics (cont.)

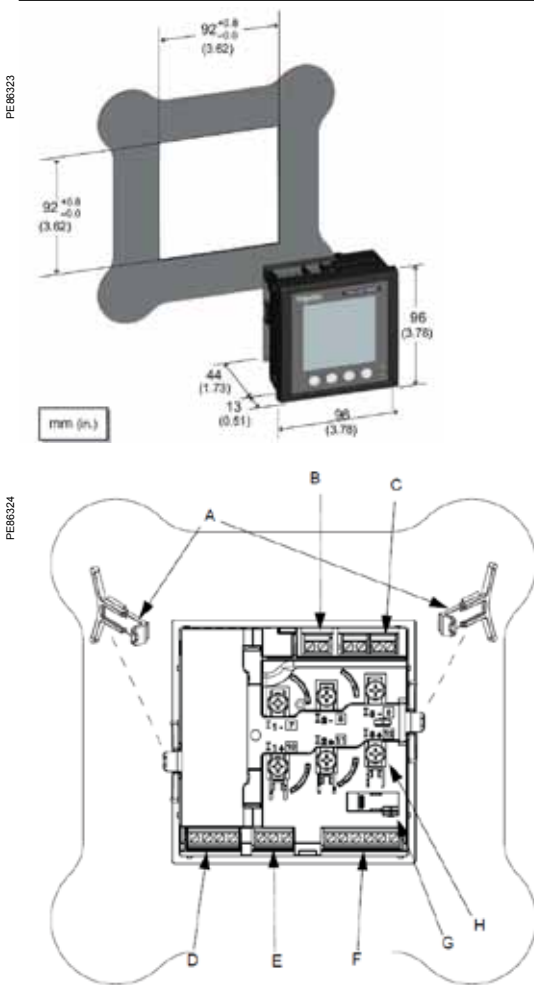

PM5350 meter parts

- A Retainer clips.
- B Control power supply connector.
- C Voltage inputs.
- D Digital outputs.
- E Rs485 port (COM1).
- F Digital outputs.
- G Optical revenue switch.
- H Current inputs.

General		
Use on LV and MV systems		■
Basic metering with THD and min/max readings		■
Instantaneous rms values		
Current	Total, Phases and neutral	■
Voltage	Total, Ph-Ph and Ph-N	■
Frequency		■
Real, reactive, and apparent power	Total and per phase	Signed
True Power Factor	Total and per phase	Signed, Four Quadrant
Displacement PF	Total and per phase	Signed, Four Quadrant
Unbalanced I, VL-N, VL-L		■
Energy values		
Accumulated Active, Reactive and Apparent Energy	Received/Delivered; Net and absolute;	■
Demand values		
Current average	Present, Last, Predicted, Peak, & Peak Date Time	■
Active power	Present, Last, Predicted, Peak, & Peak Date Time	■
Reactive power	Present, Last, Predicted, Peak, & Peak Date Time	■
Apparent power	Present, Last, Predicted, Peak, & Peak Date Time	■
Peak demand with timestamping D/T for current & powers		■
Demand calculation	Sliding, fixed and rolling block, thermal	■
Synchronization of the measurement window		■
Other measurements		
I/O timer		■
Operating timer		■
Active load timer		■
Alarm counters		■
Power quality measurements		
THD, thd (Total Harmonic Distortion)	I, VLN, VLL	
TDD, thd (Total Demand Distortion)		■
Data recording		
Min/max of instantaneous values, plus phase identification		■
Alarms with 1s timestamping	Standard 29; Unary 4; Digital 4	
Alarms stored in non-volatile memory	40 events	■
Inputs/Outputs		
Digital inputs	4 (DI1, DI2, DI3, DI4)	
Digital outputs	2 relay outputs (DO1, DO2)	
Display		
White backlit LCD display, 6 lines, 4 concurrent values		■
IEC or IEEE visualization mode		■
Communication		
Modbus RTU, Modbus ASCII, Jbus Protocol		■
Firmware update via RS485 serial port (DLF3000 via the Schneider Electric website: www.schneider-electric.com)		■

PM5350

Functions and characteristics (cont.)



Front screen view of PM5350.

Electrical characteristics		
Type of measurement		True rms up to the 15th harmonic on three-phase (3P, 3P + N) 32 samples per cycle, zero blind
Measurement accuracy	Current, Phase ⁽¹⁾	±0.30%
	Voltage, L-N ⁽¹⁾	±0.30%
	Power Factor ⁽¹⁾	±0.005
	Power, Phase	IEC 61557-12 Class 0.5; For 5 A nominal CT (for 1 A nominal CT when I > 0.15A) ±0.5% from 0.25 A to 9.0 A at COS φ = 1 ±0.6% from 0.50 A to 9.0 A at COS φ = 0.5 (ind or cap)
	Frequency ⁽¹⁾	±0.05%
Real Energy		IEC 62053-22 Class 0.5S; IEC 61557-12 Class 0.5; For 5 A nominal CT (for 1 A nominal CT when I > 0.15A) ±0.5% from 0.25 A to 9.0 A at COS φ = 1 ±0.6% from 0.50 A to 9.0 A at COS φ = 0.5 (ind or cap) IEC 61557-12 Class 0.5
Reactive Energy		IEC 62053-23 Class 3, IEC 61557-12 Class 2 For 5 A nominal CT (for 1 A nominal CT when I > 0.15A) ±2.0% from 0.25 A to 9.0 A at SIN φ = 1 ±2.5% from 0.50 A to 9.0 A at SIN φ = 0.5 (ind or cap)
Data update rate		1 second nominal (50/60 cycles)
Input-voltage	VT primary	1.0 MV AC max, starting voltage depends on VT ratio.
	U nom	277 V L-N
	Measured voltage with overrange & Crest Factor	IEC: 20 to 690 V AC L-L; 20 to 400 V AC L-N UL: 20 to 300 V AC L-L
	Permanent overload	700 Vac L-L, 404 Vac L-N
	Impedance	10 M Ω
	Frequency range	45 to 70 Hz
	Input-current	CT ratings
	Measured voltage with overrange & Crest Factor	5 mA to 9 A
	Withstand	Continuous 20 A, 10 sec/hr 50 A, 1 sec/hr 500 A
	Impedance	< 0.3 mΩ
	Frequency range	45 to 70 Hz
	Burden	< 0.024 VA at 9 A
	AC control power	Operating range
	Burden	4.1 VA / 1.5 W typical, 6.7 VA / 2.7 W max at 120 V AC 6.3 VA / 2.0 W typical, 8.6 VA / 2.9 W max at 230 V AC 9.6 VA / 3.5 W maximum at 265 V AC
	Frequency	45 to 65 Hz
	Ride-through time	100 mS typical at 120 V AC and maximum burden 400 mS typical at 230 V AC and maximum burden
	DC control power	Operating range
	Burden	1.4 W typical, 2.6 W maximum at 125 V DC 1.8 W typical, 2.7 W maximum at 250 V DC 3.2 W maximum at 300 V DC
	Ride-through time	50 mS typical at 125 V DC and maximum burden
	Real time clock	Ride-through time
Digital output	Number/Type	2 - Mechanical Relays
	Output frequency	0.5 Hz maximum (1 second ON / 1 second OFF - minimum times)
	Switching Current	250 V AC at 2.0 Amps, 200 k cycles, resistive 250 V AC at 8.0 Amps, 25 k cycles, resistive 250 V AC at 2.0 Amps, 100 k cycles, COSφ=0.4 250 V AC at 6.0 Amps, 25 k cycles, COSφ=0.4 30 V DC at 2.0 Amps, 75 k cycles, resistive 30 V DC at 5.0 Amps, 12.5 k cycles, resistive
	Isolation	2.5 kVrms
	Status Digital Inputs	Voltage ratings
	Input Resistance	110 k Ω
	Maximum Frequency	2 Hz (T ON min = T OFF min = 250 ms)
	Response Time	10 ms
	Isolation	2.5 kVrms
Whetting output	Nominal voltage	24 V DC
	Allowable load	4 mA
	Isolation	2.5 kVrms

(1) Measurements taken from 45 Hz to 65 Hz, 0.5 A to 9 A, 57 V to 347 V & 0.5 ind to 0.5 cap power factor with a sinusoidal wave.

PM5350

Functions and characteristics (cont.)

Mechanical characteristics		
Weight		250 g
IP degree of protection (IEC 60529)		IP51 front display, IP30 meter body
Dimensions	W x H x D	96 x 96 x 44 mm (depth of meter from housing mounting flange) 96 x 96 x 13 mm (protrusion of meter from housing flange)
Mounting position		Vertical
Panel thickness		6.35 mm maximum
Environmental characteristics		
Operating temperature	Meter	-25 °C to 70 °C
	Display	-20 °C to +70 °C (Display functions to -25°C with reduced performance)
Storage temp.	Meter + display	-40 °C to +85 °C
Humidity rating		5 to 95 % RH at 50 °C (non-condensing)
Pollution degree		2
Altitude		3000 m max.
Electromagnetic compatibility		
Electrostatic discharge		IEC 61000-4-2 ⁽²⁾
Immunity to radiated fields		IEC 61000-4-3 ⁽²⁾
Immunity to fast transients		IEC 61000-4-4 ⁽²⁾
Immunity to impulse waves		IEC 61000-4-5 ⁽²⁾
Conducted immunity		IEC 61000-4-6 ⁽²⁾
Immunity to magnetic fields		IEC 61000-4-8 ⁽²⁾
Immunity to voltage dips		IEC 61000-4-11 ⁽²⁾
Radiated emissions		FCC part 15 class A, EN 55011 Class A
Conducted emissions		FCC part 15 class A, EN 55011 Class A
Harmonics		IEC 61000-3-2 ⁽²⁾
Flicker emissions		IEC 61000-3-3 ⁽²⁾
Safety		
Europe		CE, as per IEC 61010-1
U.S. and Canada		cULus as per UL61010-1, IEC 61010-1 (2nd Edition)
Measurement category (Voltage and current inputs)		Per IEC 61010-1: CAT III, 277 V L-N / 480 V L-L ⁽¹⁾ nominal; CAT II 400 V L-N / 690 V L-L ⁽¹⁾ nominal Per UL 61010-1 and CSA C22.2 No. 61010-1: CAT III, 300 V L-L
Overvoltage Category (Control power)		CAT III
Dielectric		As per IEC 61010-1 Double insulated front panel display
Protective Class		II
Communication		
RS 485 port		2-Wire, 9600, 19200 or 38400 baud, Parity - Even, Odd, None, 1 stop bit if parity Odd or Even, 2 stop bits if None; Modbus RTU, Modbus ASCII (7 or 8 bit), JBUS
Firmware and language file update		Update via communication port using DLF3000 software
Isolation		2.5 kVrms, double insulated
Human machine interface		
Display type		Monochrome Graphics LCD
Resolution		128 x 128
Backlight		White LED
Viewable area (W x H)		67 x 62.5 mm
Keypad		4-button
Indicator Heartbeat / Comm activity		Green LED
Energy pulse output / Active alarm indication (configurable)		
Type		Optical, amber LED
Wavelength		590 to 635 nm
Maximum pulse rate		2.5 kHz

(1) V L-L is limited to 700 V AC

(2) As per IEC 61557-12

PM5350 Power Meter

Installation and connection

Rear of meter - open

PE88279



Rear view retainers - installation

PE88274

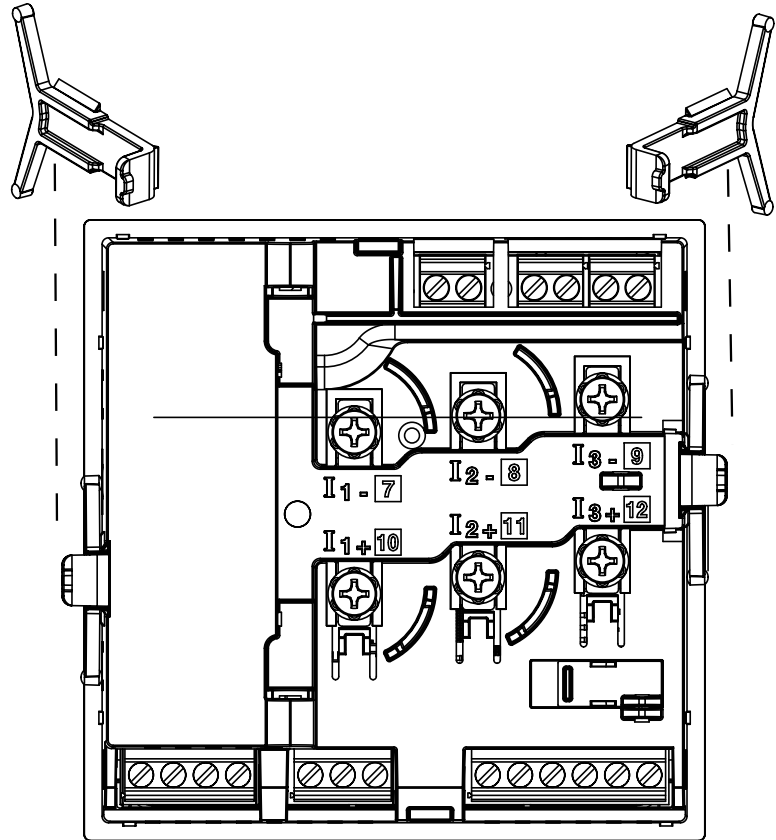

For detailed installation instructions see the product's Installation guide.

PM5350 Power Meter

Installation and connection (cont.)

Rear view retainers - users

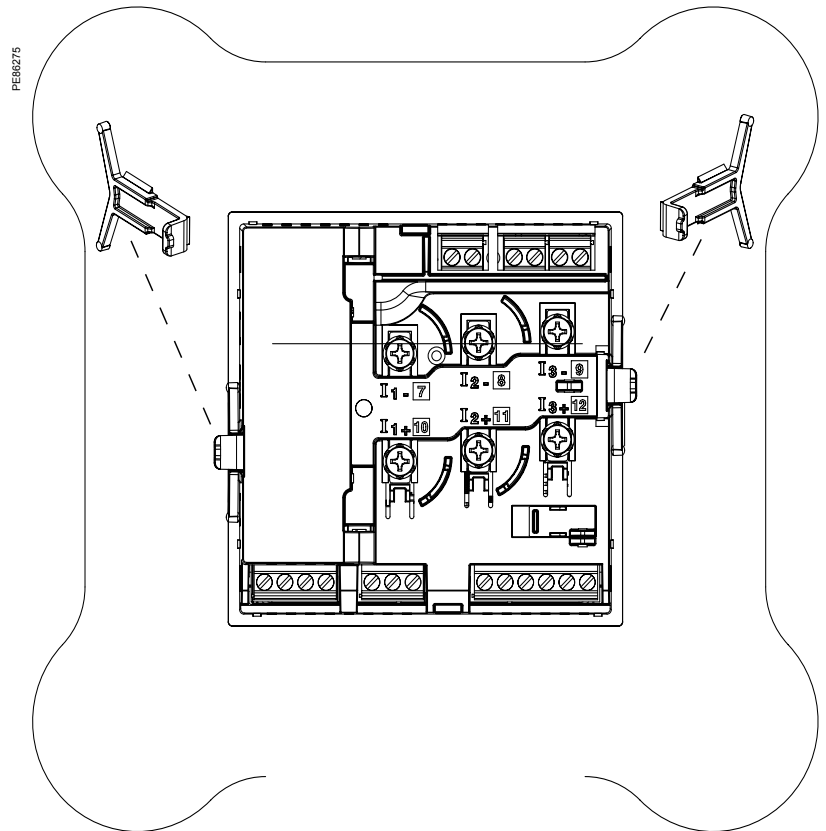

For detailed installation instructions see the product's Installation guide.

RS485 daisy-chain connection

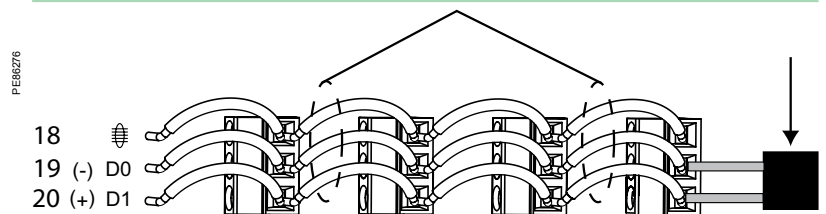

- If the power meter is the first device on the daisy chain, connect it to the host device using a RS232 to RS422/RS485 converter.
- If the power meter is the last device on the daisy chain, terminate it with the terminator provided.
- The terminal's voltage and current ratings are compliant with the requirements of the EIA RS485 communications standard.

For detailed installation instructions see the product's Installation and reference guides.

PM5350 Power Meter

Installation and connection (cont.)

NOTE: This is a small sample of wiring diagrams - many more system types are supported.

Single Phase L-L 2 Wire 1 CT wiring diagram

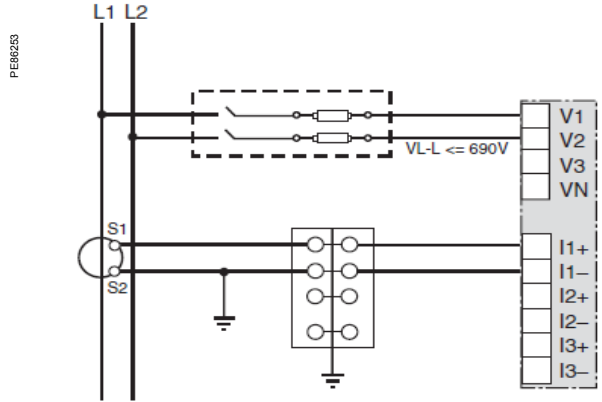

- Use with 120/240V systems.

PM5350 input/output capabilities

The PM5350 has four (4) digital inputs and two (2) mechanical relay outputs. The digital inputs have two (2) operating Modes: Normal and Demand Sync. The relay outputs have three (3) operating modes: External Control (default), Alarm, and Demand Sync. When configured in Alarm mode, the digital output can be controlled by the meter in response to an alarm condition.

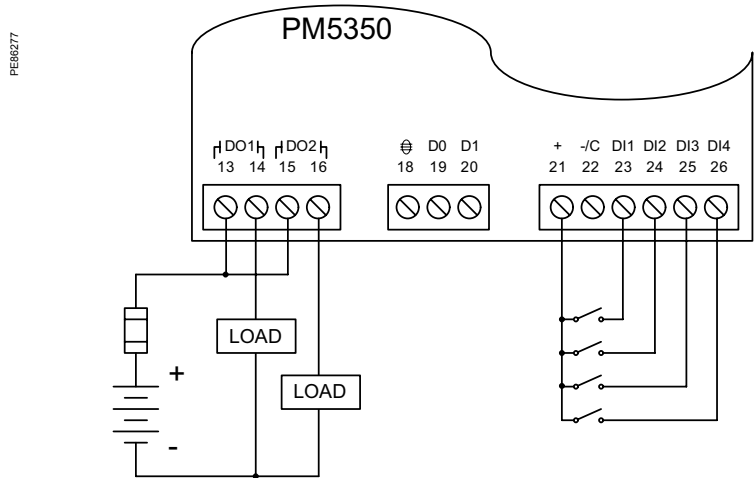

- (1) Digital inputs and outputs are not SELV rated.
- (2) Overcurrent protective device must be rated for the short-circuit currents at connection point.

PM5350 Power Meter

Installation and connection (cont.)

NOTE: This is a small sample of wiring diagrams - many more system types are supported.

3 Phase 3 Wire 2 VT 1 CT wiring diagram

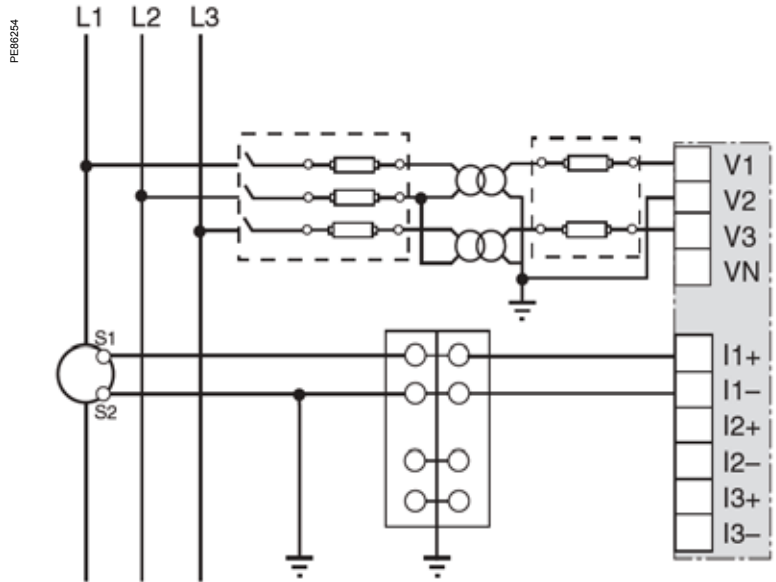

3 Phase 4 Wire WYE 3 VT 1 CT wiring diagram

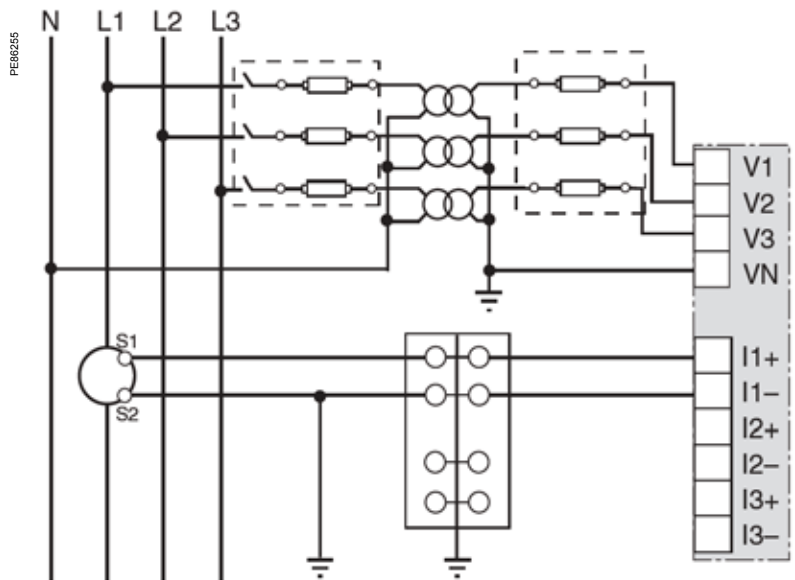

Schneider Electric Industries SAS
35 Rue Joseph Monier
CS 30323
F- 92506 Neuilly Malmaison Cedex

RCS Nanterre 954 503 439
Capital social 896 313 776 €
www.schneider-electric.com

As standards, specifications and designs change from time to time, please ask for confirmation of the information given in this publication.



Printed on recycled paper.

Design : Schneider Electric
Production : Schneider Electric EM
Publishing : Altavia Connexion - made in France